

# vanguard®

## applications

- Assembly lines
- Production areas
- Gymnasia
- Swimming pools
- Clean areas
- Food processing areas

Vanguard® is the solution for applications with extremely arduous environmental conditions. This luminaire is particularly robust and utilises a combination of an aluminium reflector and a prismatic glass refractor providing wide spacing characteristics and exceptional glare control. Two sizes offer the flexibility to use Vanguard® for both high and low mounting heights. The IP65 version Vanguard® Plus with a polycarbonate visor spun over the glass refractor make Vanguard® plus suitable for applications such as the food industry or other 'clean' areas.

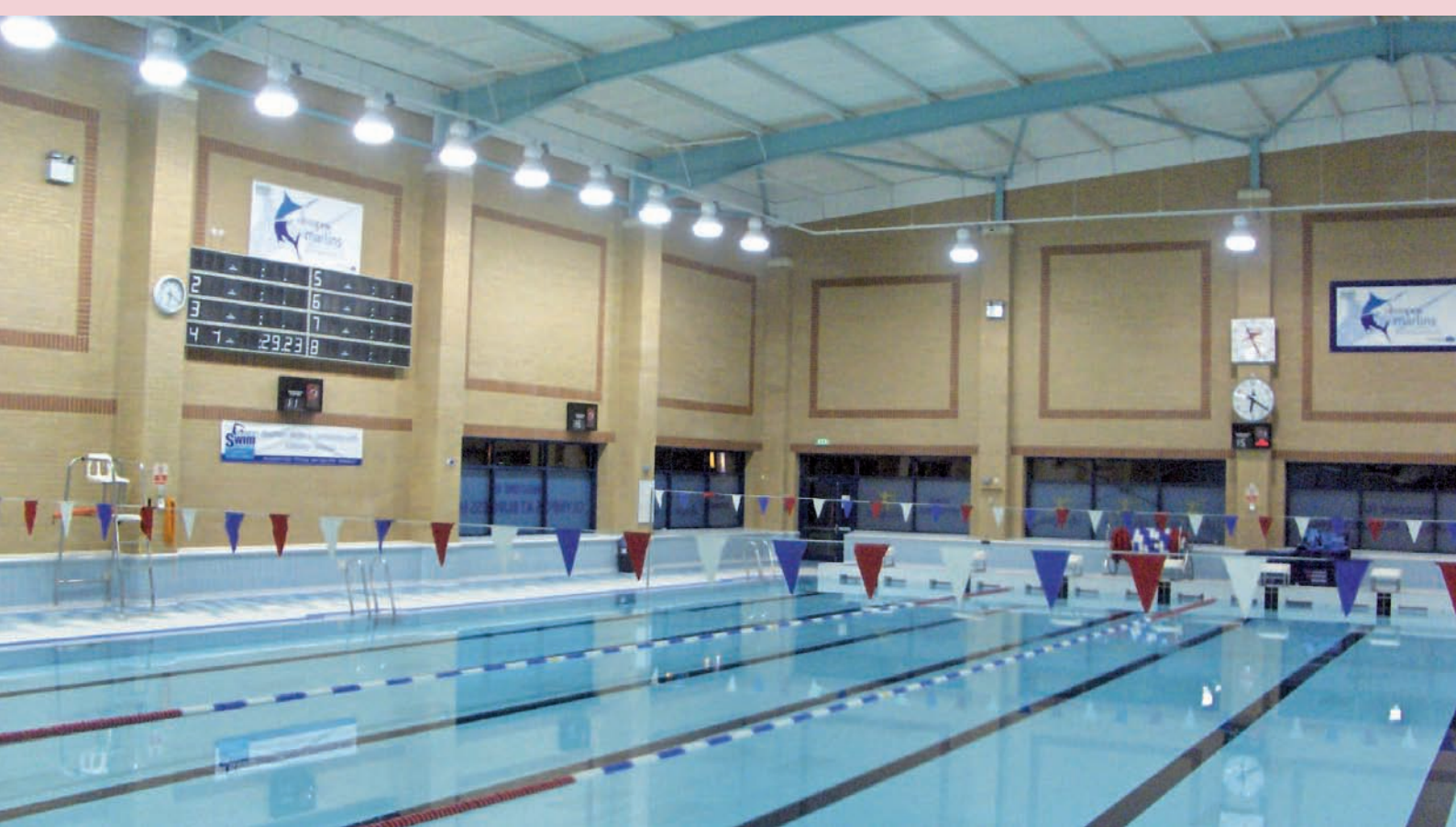

**features and benefits**

- Totally enclosed luminaire
  - > Minimal dirt ingress
- Efficient prismatic refractor
  - > Optimum light output
- Wide spacing characteristics
  - > Reduced number of luminaires required
- Uniform refractor luminance
  - > Reduced glare
- Two sizes
  - > Suitable for high and low mounting heights
- IP65 option
  - > Suitable for clean areas
- Vanguard Plus with polycarbonate visor
  - > Suitable for food industry

**lamp types included****small vanguard**

- 70W - 150W metal halide (various)
- 70W - 150W high pressure sodium

**large vanguard**

- 250W - 450W metal halide (various)
- 150W - 400W high pressure sodium

**IP rating**

- IP20 (standard)
- IP65 (with .WL or .C option) 

**approvals**

Complies with EN60598



CE

large vanguard



small vanguard



**specification**

The luminaire shall comprise of a prismatic borosilicate refractor onto which an aluminium reflector is spun. The optical assembly shall be suspended from the gear capsule by means of two sliding latches. Depending on the size of lamp used, a choice of either a spherical or rectangular gear capsule shall be used consisting of a two-part die-cast aluminium assembly suitable to operate a choice of high intensity discharge lamps, with electrical supply to the capsule by means of a plug and socket arrangement. The luminaire complies with EN60598, with an IP rating of 20. The luminaire shall be IP65 for wet location version only and shall be available with a polycarbonate refractor cover for food factory applications.

**light distributions**

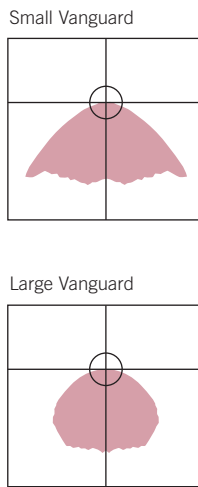

Photometric data is available at [www.holophane.co.uk](http://www.holophane.co.uk)

**weights & thermal data**

Lamp Type	Weight (kg)	Min. Operating Temperature (°C)	Max. Ambient Temperature (°C)
70W High Pressure Sodium	10.0	-30	60
100W High Pressure Sodium	10.5	-30	50
150W High Pressure Sodium	11.0	-30	45
250W High Pressure Sodium	18.5	-30	40
400W High Pressure Sodium	19.5	-30	40
100W Metal Halide	10.5	-20	40
150W Metal Halide	11.0	-20	35
250W Metal Halide	18.5	-20	40
400W Metal Halide	19.5	-20	40

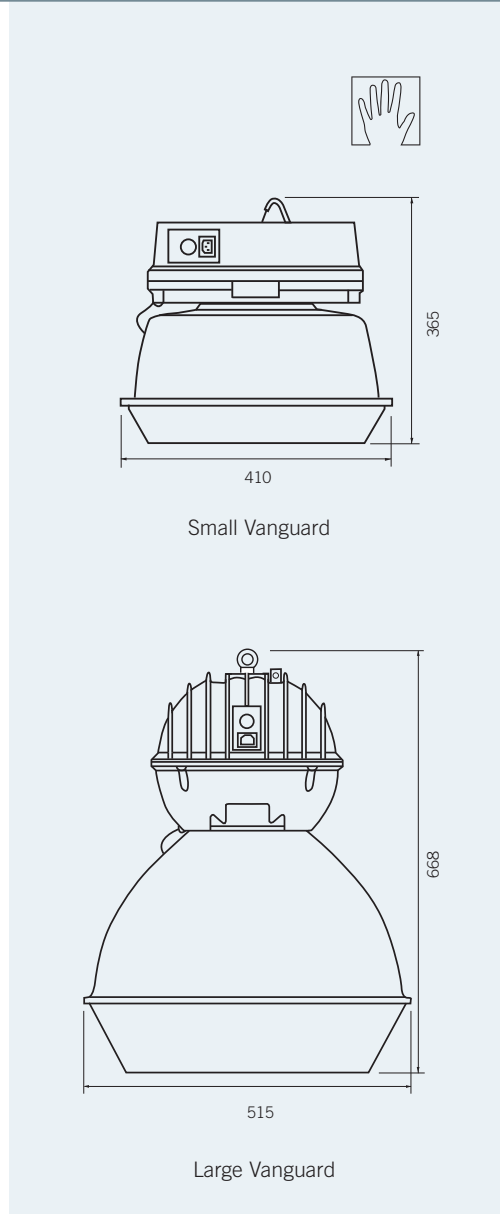



vanguard®

## ordering details : luminaire

**Code**

VGS	Small Vanguard
VPS	Small Vanguard Plus (with polycarbonate visor for use in food industry)

Code	Lamp type
.70XT	70W Clear High Output HPS Lamp (E27) Base
.100XT	100W Clear High Output HPS Lamp (E40) Base
.150XT	150W Clear High Output HPS Lamp (E40) Base
.100MA	100W Clear 3700K Protected Metal Halide Lamp (E27) Base
.150MA	150W Clear 3700K Protected Metal Halide Lamp (E27) Base

Code	Options
.B	Flush Mounting Bracket
.M	Electronic Relay Circuit
.WL	Wet Location (IP54 capsule)
.CA	Safety Chain Attachment (Chain by Others)
.PO1	Customer Auxiliary Lamp Supply 230/240V
.IG	Timed Ignitor
.RAL****	RAL Colour (customer choice)
.DO1	Suitable for a maximum ambient temperature of 50 degrees

**Example** VGS .70XT .B

**Code**

VGL	Large Vanguard
VPL	Large Vanguard Plus (with polycarbonate visor for use in food industry)

Code	Lamp type
.150XT	150W Clear High Output HPS Lamp (E40) Base
.250XT	250W Clear High Output HPS Lamp (E40) Base
.400XT	400W Clear High Output HPS Lamp (E40) Base
.250HDPSP	250W Coated 3700K Protected Pulse Start Metal Halide Lamp (E40) Base
.400HDPSP	400W Coated 3700K Protected Pulse Start Metal Halide Lamp (E40) Base
.250HDP	250W Coated 5000K Protected Metal Halide Lamp (E40) Base
.400HDP	400W Coated 5000K Protected Metal Halide Lamp (E40) Base
.450HDVP	450W Coated 3700K Protected Metal Halide Lamp (E40) Base
.400MVD	400W Multi Vapour Coated 3700K Unprotected Metal Halide Lamp (E40) Base

Code	Options
.B	Flush Mounting Bracket*
.M	Electronic Relay Circuit
.WL	Wet Location (IP54 capsule)
.CA	Safety Chain Attachment (Chain by Others)
.PO1	Customer Auxiliary Lamp Supply 230/240V
.IG	Timed Ignitor
.RAL****	RAL Colour (customer choice)
.Q	Catenary Mounting Bracket*
.YO1	Complete with 3 hour sustained emergency battery + inverter
.DO1	Suitable for a maximum ambient temperature of 50 degrees

**Example** VGL .150XT .B

\* .Q & .B not available together

## ordering details : luminaire accessories &amp; options



## luminaire accessories &amp; options

order separately for on site installation by others

## Code

<b>VG.D.G1</b>	Wire Guard for Small Vanguard/ Vanguard
<b>VG.D.G2</b>	Wire Guard for Large Vanguard/Vanguard Plus
<b>HEL.OK</b>	Open/Closed Loop Adaptor (Karabiner)***
<b>HEL.LOOP</b>	Suspension Loop

\*\*\* Large Vanguard / Vanguard Plus only

## options



.B (small Vanguard)  
Flush mounting bracket



.B (large Vanguard)  
Flush mounting bracket



.WL (large Vanguard)  
Wet location (IP54  
capsule)



.CA (large Vanguard)  
Safety chain attachment



.M (large Vanguard)  
Electric relay circuit with  
standby lamp



.Q (large Vanguard)  
Catenary mounting  
bracket

## accessories



HEL.OK  
Open/closed loop  
adaptor (Karabiner)

