

# vantage™

## applications

- Assembly lines
- Production areas
- Swimming pools
- Clean areas
- Food processing areas
- Sports halls

Vantage™ is a highly efficient luminaire specifically designed for clean areas with a unique, high temperature acrylic reflector/refractor optical assembly. The wide light distribution provides excellent balance for both vertical and horizontal tasks, with the upward light component providing a comfortable visual environment. The smooth profile of the control gear housing minimises accumulation of foreign matter and ensures easy cleaning. With an IP655 rating, Vantage™ is suitable for the most arduous of food and 'clean' environments. A special gasket sealed lamp access door allows easy access for re-lamping.



**features and benefits**

Unique reflector and refractor optic

- > Suitable for clean areas

Hose-down facility (IP655)

- > Easy to clean

Wide Spacing Characteristics

- > Reduced number of luminaires

Gasket sealed lamp access door

- > Easy maintenance

**lamp types included**

250W - 450W metal halide (various)

250W - 400W high pressure sodium

**IP rating**

IP655 

**approvals**

Complies with EN60598

CE

**Hose Down Protection**

Vantage can be hosed down at up to 3500 psi from a distance of 1.2m without leakage making it the ideal product for food factory environments.



Easy maintenance through lamp access door



### specification

The luminaire shall consist of a unique prismatic high temperature acrylic refractor and internal aluminium reflector assembly complete with a removable door for lamp access. The assembly shall be suspended from the gear capsule by means of four fixing screws located within the internal reflector. The control gear housing shall consist of a single die-cast aluminium assembly suitable to operate a choice of high intensity discharge lamps. The design of the luminaire shall be such that there are no external ledges or traps that will collect debris when installed. The luminaire complies with EN60598 with an IP rating of 655. The Luminaire is supplied with M25 threaded entry with tube suspension (by others) as standard.

### light distributions

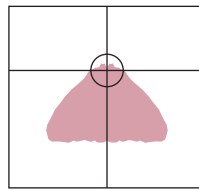

Photometric data is available at [www.holophane.co.uk](http://www.holophane.co.uk)

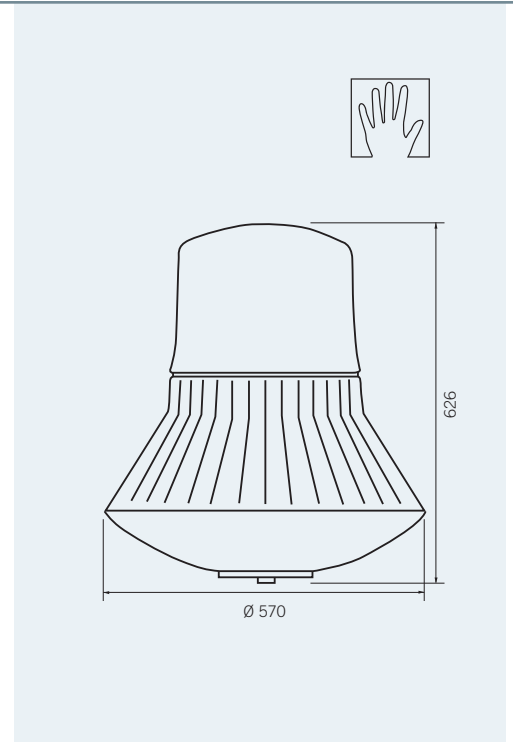

### weights & thermal data

Lamp Type	Weight (kg)	Min. Operating Temperature (°C)	Max. Ambient Temperature (°C)
250W High Pressure Sodium	19	-30	45
400W High Pressure Sodium	19	-30	40
250W, 400W, 450W Metal Halide	19	-20	35



vantage™

## ordering details : luminaire

## Code

Code	Vantage	
VTG		
	<b>Code</b>	<b>Lamp Type</b>
	.250XD	250W Coated High Output HPS Lamp (E40) Base
	.400XD	400W Coated High Output HPS Lamp (E40) Base
	.250XT	250W Clear High Output HPS Lamp (E40) Base
	.400XT	400W Clear High Output HPS Lamp (E40) Base
	.250HDP	250W Coated 5000K Protected Metal Halide Lamp (E40) Base
	.400HDP	400W Coated 5000K Protected Metal Halide Lamp (E40) Base
	.250HDPSP	250W Coated 3700K Protected Pulse Start Metal Halide Lamp (E40) Base
	.400HDPSP	400W Coated 3700K Protected Pulse Start Metal Halide Lamp (E40) Base
	.250HTPSP	250W Clear 4000K Protected Pulse Start Metal Halide Lamp (E40) Base
	.400HTPSP	400W Clear 4000K Protected Pulse Start Metal Halide Lamp (E40) Base
	.450HDVP	450W Coated 3700K Protected Metal Halide Lamp (E40) Base
	.450HTVP	450W Clear 4000K Protected Metal Halide Lamp (E40) Base
		<b>Code</b> <b>Options</b>
	.M	Electronic Relay Circuit
	.SH	Suspension Hook
	.CA	Safety Chain Attachment**
	.PO1	Lamp for customer auxiliary 230/240v supply
	.IG	Timed Ignitor
	.RAL****	RAL Colour (customer choice)†
<b>Example</b>	VTG	.400HDPSP .IG

\*\*Chain supplied by others. †Please specify RAL colour reference. Note: Luminaires are supplied as standard for use on 240V 50Hz supply, and complete with lamp. For 230V 50Hz add prefix 'N' Other supply variations available on request.