

# ARONA BENCH

## "No Back / No Sides"

The bench is made up of the following components:

- A) Two flush Cast iron sides with built in ground fixing strut.
- B) One 1500mm Long, Ø33mm Steel strengthening cross member with M10 fixings
- C) 7 off wooden Iroko slats of which 4 are (1480x50x33mm) and 3 are (1480x100x33mm) supplied with suitable stainless steel screws, washers and nuts for fixing.

Overall Height: 450mm  
Overall Length: 1560mm  
Length: 1500mm  
Width: 370mm

Note: The bench is delivered in component format and must be assembled on site by others

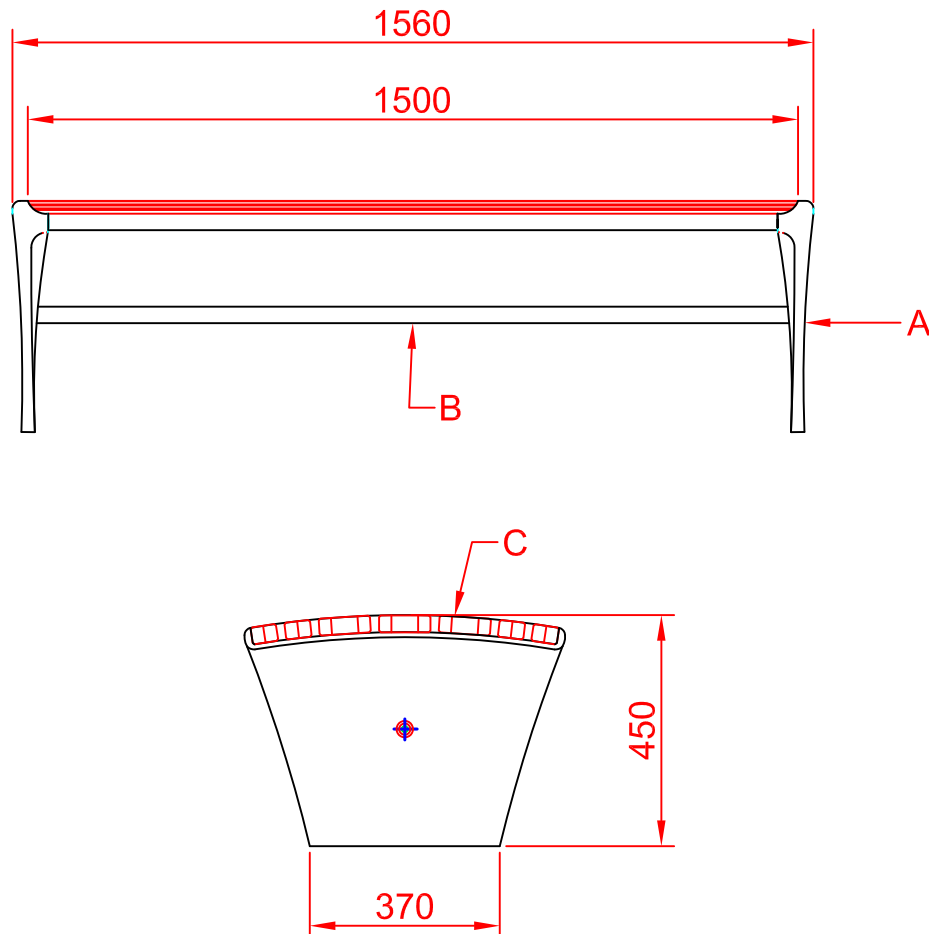

Certification: UNI EN ISO 9001:2000

Sch06: technical card of specifications  
Revision: 01 - Date Rev. 22/10/2004 - Scale: 1:15  
SCH06\_ARONA BENCH "No Back - No Sides"\_R00

Holophane Europe Ltd  
Bond Avenue, Milton Keynes, MK1 1JG, United Kingdom  
Tel : +44 (0) 1908 649292 Fax : +44 (0) 1908 367618  
e-mail : [info@holophane.co.uk](mailto:info@holophane.co.uk)  
web : [www.holophane.co.uk](http://www.holophane.co.uk) or [www.holophane.eu.com](http://www.holophane.eu.com)

  
**HOLOPHANE**<sup>®</sup>  
LEADER IN LIGHTING SOLUTION



HELLS AMESTER



ERROR: syntaxerror  
OFFENDING COMMAND: --nostringval--

STACK:

/Title  
( )  
/Subject  
(D:20041230114406)  
/ModDate  
( )  
/Keywords  
(PDFCreator Version 0.8.0)  
/Creator  
(D:20041230114406)  
/CreationDate  
(Venturi Denis)  
/Author  
-mark-